

Thank you for purchasing the JUXTA Signal Conditioner.  
Please read through this manual before use for correct handling.

## CAUTIONARY NOTES FOR SAFE USE OF THE PRODUCT

This User's Manual should be carefully read before installing and operating the product. Please keep this User's Manual for future reference.

The following symbol is used on the product and in this manual to ensure safe usage.



**This symbol is displayed on the product when it is necessary to refer to the User's Manual for information on personal and instrument safety. This symbol is displayed in the User's Manual to indicate precautions to avoid danger to the operator, such as an electric shock.**

The following symbols are used only in this manual.



### NOTE

**Draws attention to essential information for understanding the operations and/or functions of the product.**

## CHECKING PRODUCT SPECIFICATIONS AND PACKAGE

### (1) Checking the Model and Product Specifications

Check that the model and specifications indicated on the nameplate attached to the main unit are as ordered.

### (2) Packaged Items

Check that the package contains the following items:

- WA5A or WA5V: 1
- Mounting block: 2
- Tag number label : 1
- Mounting screw (M4 x 0.7): 4
- User's Manual (this manual: IM 77J09A05-01E)

## GENERAL

The WA5A/WA5V is a compact, front terminal connection type distributor with square root extractor, is used in combination with a two-wire transmitter to convert the differential pressure flow signal into a linearized signal proportional to the flow.

- Low cut point setting, zero/span adjustment, and I/O monitoring can be made using optional Parameter Setting Tool (VJ77) or Handy Terminal (JHT200).

Yokogawa Electric Corporation  
**Network Solutions Business Division**  
2-9-32, Naka-cho Musashino-shi, Tokyo 180-8750 Japan  
Phone: +81-422-52-7179 Facsimile: +81-422-52-6619

## MODEL AND SUFFIX CODES

Model	Suffix codes	Description
WA5A	-□ □ □ °C	Distributor
WA5V		(with square root extractor)
Input	-A	4 to 20 mA DC Transmitter power supply 25.25 ± 0.25V DC
Output	A	4 to 20 mA DC
	B	2 to 10 mA DC
	C	1 to 5 mA DC
	D	0 to 20 mA DC
	E	0 to 16 mA DC
	F	0 to 10 mA DC
	G	0 to 1mA DC
	Z	(Custom order) DC current signal
	1	0 to 10 mV DC
	2	0 to 100 mV DC
	3	0 to 1 V DC
Power supply	-1	24V DC ± 10%
	-2	100-240 V AC (-15%, +10%) 50/60 Hz
	Style code	°C Style C

## 1. MOUNTING METHOD

### 1.1 Installing/Uninstalling the Mounting Block

The mounting block is necessary for rack mounting or wall mounting.

#### Installing the mounting block

- Fit the mounting block into the grooves of the converter, and slide it in the direction of an arrow as shown below-left.

#### Uninstalling the mounting block

- Lift the stopper using a slotted screw-driver as shown below-right, and pull the mounting block to remove it.

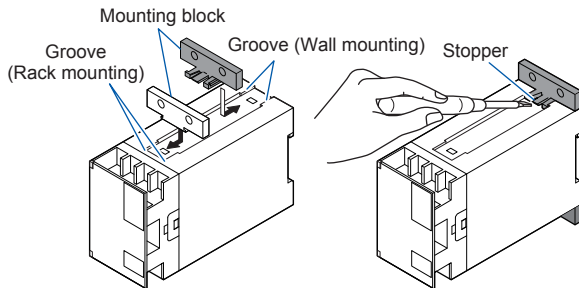

### 1.2 Rack Mounting

Take the FRK panel and install it on a mounting angle as shown below.

This method is suitable for high density mounting of the converters on a 19-inch rack panel.

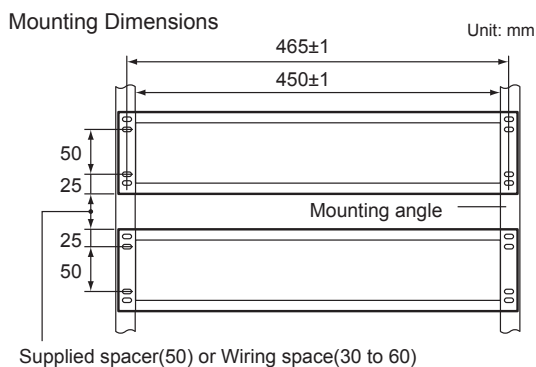
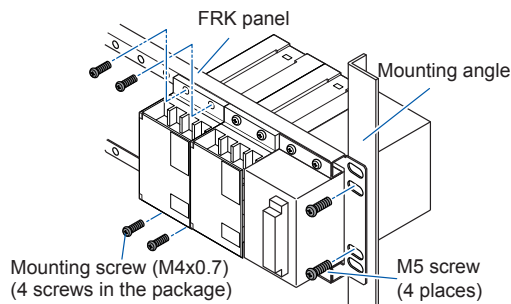

### 1.3 Wall Mounting

Mount the converter onto the FRK panel as shown below or mount it directly on the wall.

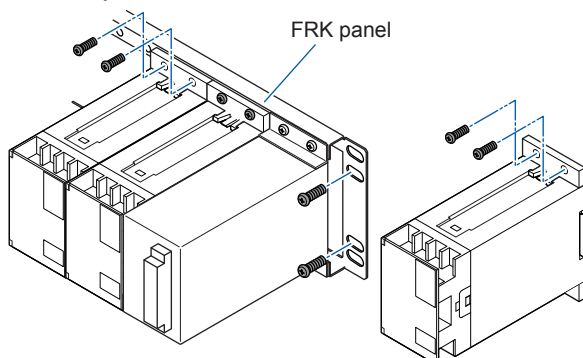

### 1.4 DIN Rail Mounting

Place the converter so that the DIN rail fits into the upper part of the DIN-rail groove at the rear of the converter, and push until it clicks. The converter is fixed by a slide lock (at the lower part on the rear side of the converter).

To remove the converter, pull down the slide lock using a slotted screw-driver.

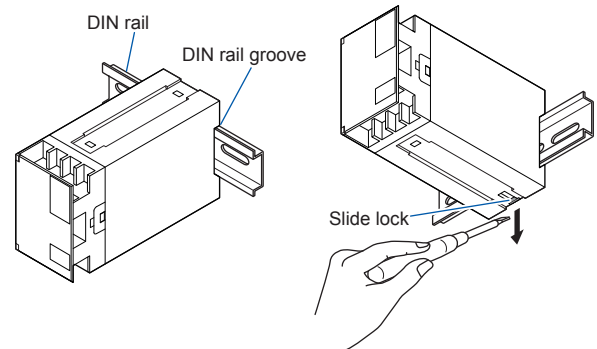

### 1.5 Mounting Dimensions

Unit: mm

#### Angle Mounting Dimensions

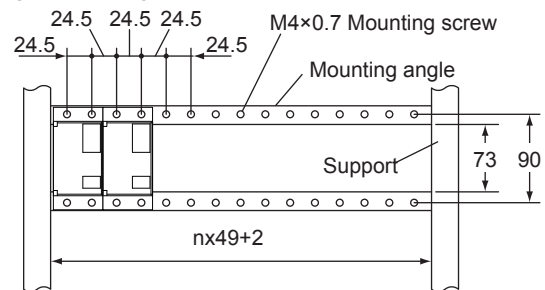

#### Wall Mounting Dimensions

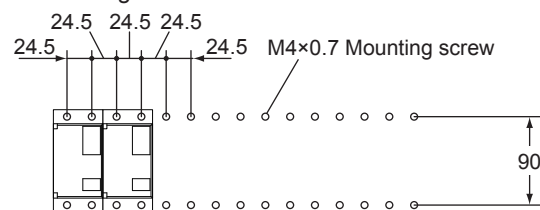

## 2. INSTALLATION LOCATION

- Avoid the following environments for installation locations: Areas with vibration, corrosive gases, dust, water, oil, solvents, direct sunlight, radiation, a strong electric field, and/or a strong magnetic field, altitude of more than 2000m above sea level.
- If there is any risk of a surge being induced into the power line and/or signal lines due to lightning or other factors, a dedicated lightning arrester should be used as protection for both this converter and a field-installed device.
- Operating temperature/humidity range: 0 to 50°C/5 to 90%RH (no condensation)

## 3. EXTERNAL WIRING



### WARNING

**Be sure to turn OFF the power supply before wiring to avoid the risk of electric shock. Use a tester or similar device to ensure that no power is being supplied to a cable to be connected.**

M4 screw terminals are provided for the connection of external signals. Attach a crimp-on lug to each wire for connection to the terminals.

- Recommended cables: A nominal cross-sectional area of 0.5 mm<sup>2</sup> or thicker for signal cables, and that of 1.25 mm<sup>2</sup> or thicker for power cables.

## Wiring Diagram

Input

- When using internal power supply

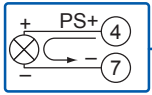

- When using external power supply

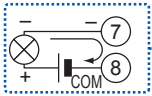

Power supply

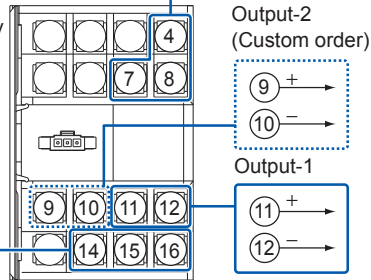
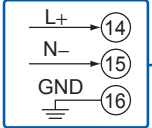

Output-2  
(Custom order)

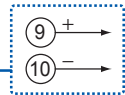

Output-1

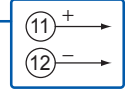

### NOTE

- Do not connect anything to the terminals that are not used in the wiring diagram. Otherwise it may cause the malfunction or damage.
- The power line and input/output signal lines should be installed away from noise-generating sources. Otherwise accuracy cannot be guaranteed.
- The grounding resistance must be 100Ω or less (JIS Class D grounding). The length and thickness of the grounding cable should be as short and thick as possible. Directly connect the lead from the ground terminal ⑯ of the product to the ground. Do not carry out daisy chained inter-ground terminal wiring.
- The ground terminal ⑯ becomes effective for AC power only.
- Adhere strictly to the specifications to avoid overheating or damage. Before turning on the power, ensure the following:
  - (a) Power supply voltage and input signal value applied to the product should meet the required specifications.
  - (b) The external wiring to the terminals and wiring to ground are as specifications.
- Do not operate the product in the presence of flammable or explosive gases or vapors.
- This product is sensitive to static electricity; exercise care in handling. Before you operate the product, touch a nearby metal part to discharge static electricity.

### Power Supply and Isolation

Power supply voltage:

100 to 240V AC (-15%, +10%) 50/60Hz

24V DC ± 10% (percentage ripple: less than 5% p-p)

Current consumption (24 V DC): WA5A 100 mA, WA5V 90 mA  
 Power consumption: (100 V AC drive); WA5A 6 VA, WA5V 5 VA  
 (200 V AC drive); WA5A 8 VA, WA5V 7 VA

Insulation resistance: 100 MΩ at 500 V DC between input and output, input and power supply, input and ground, output and power supply, output and ground, and power supply and ground.

Withstand voltage:

(DC drive) 1500 V AC/min. between input and (output and power supply). 500 V AC/min. between output and power supply.

(AC drive) 1500 V AC/min. between input and output, input and power supply, input and ground, output and power supply, output and ground, and power supply and ground.

Power supply suffix codes: DC drive [-1], AC drive [-2]

## 4. SETTING PARAMETERS

The parameters are set as you specified in your order. Refer to the following to change the default settings.

Set the parameters using a PC (VJ77 Parameter Setting Tool) or the Handy Terminal. Refer to "5. List of Parameters" in this manual and the User's Manual for VJ77 PC-based Parameters Setting Tool (IM 77J01J77-01E) or the User's Manual for JHT200 Handy Terminal (IM JF81-02E). Parameters are shown in brackets "[ ]".

### Connection of Setting Tools

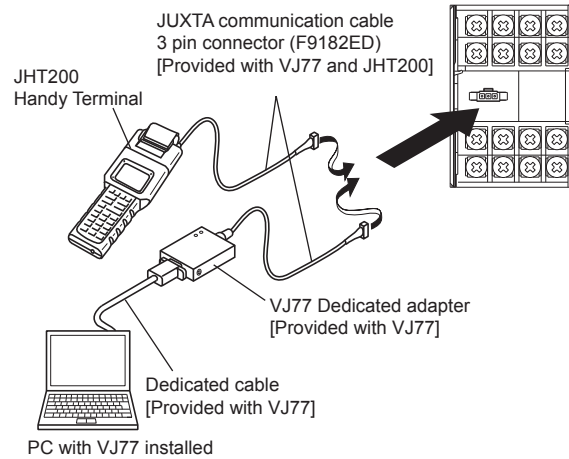

PC with VJ77 installed

\*Be sure to use the VJ77 of version R1.05 or later.

### Setting Low Cut Point

Set the low cut point in [B07: LOW CUT]

- Setting range: 0.3 to 100% of the input range (setting resolution 0.1%)

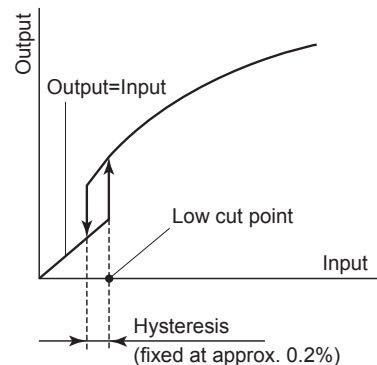

## 5. LIST OF PARAMETERS

Parameter Display	Items
<b>A</b> DISPLAY	<b>Display</b>
A01 INPUT	Input value
A02 OUTPUT	Output value
A03 STATUS	Status (*1)
A04 REV NO	Revision number
<b>B</b> SET	<b>Setting</b>
B01 TAG NO.1	Tag number 1
B02 TAG NO.2	Tag number 2
B03 COMMENT1	Comment 1
B04 COMMENT2	Comment 2
B07 LOW CUT	Low cut point
<b>C</b> ADJUST	<b>Adjustment</b>
C01 OUT 0%	Output 0% adjustment
C02 OUT 100%	Output 100% adjustment
C04 ZERO ADJ	Input zero adjustment
C05 SPAN ADJ	Input span adjustment

\*1: This "STATUS" is for the customer's engineer to check the history.

## 6. MAINTENANCE

The product starts running immediately when the power is turned on; however, it needs 10 to 15 minutes of warm-up before it meets the specified performance.

### 6.1 Calibration Apparatus

- A voltage current source (Yokogawa 7651 or equivalent)
- A digital multimeter, DMM (Yokogawa 7561 or equivalent)
- A precision resistor of  $250\Omega \pm 0.01\%$ , 1W
- A setting tool for adjustment (Refer to "4. Setting Parameters" in this manual.

### 6.2 Calibration Procedure

1. Connect the instruments as shown below.

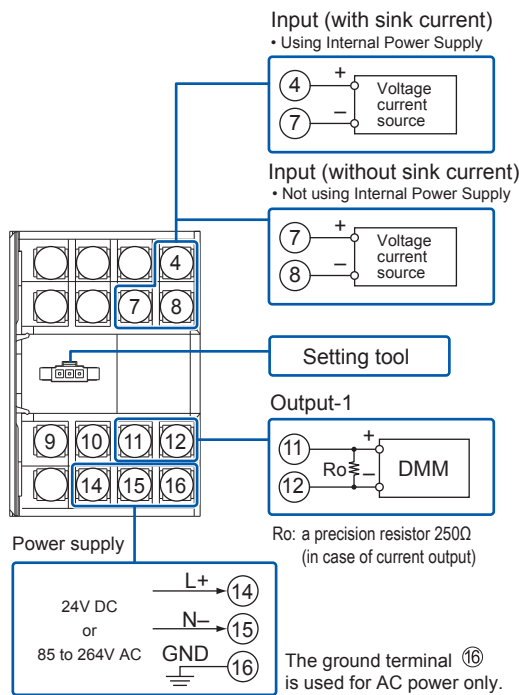

2. Use the voltage current source and apply the electromotive force equivalent to 0, 6.25, 25, 56.25, and 100% of the measuring range to the distributor.

3. Verify that the corresponding output-1 voltages are 0, 25, 50, 75, and 100% respectively and within the specified accuracy rating. (Ro is used for current output.)

For checking the output-2, connect the DMM to the output-2 terminals: ⑨ + and ⑩ -.

The relative error between output-1 and 2 is within  $\pm 0.2\%$ .

- Use the setting tool (VJ77 Parameter Setting Tool or JHT200 Handy Terminal) to adjust the input/output signals.

#### Input Adjustment Procedure

- (1) Input the value equivalent to 0% value of the input range to the distributor.
- (2) Read the parameter **[C04: ZERO ADJ]** and check the input value.
- (3) Select "INC" or "DEC" in the parameter **[C04: ZERO ADJ]** to adjust.
  - Adjust so that the indicated value and measured value of **[C04: ZERO ADJ]** become equal.
  - INC: Increase (Adjusts the increased value of the input [voltage] value)
  - DEC: Decrease (Adjusts the decreased value of the input [voltage] value)
  - RST: Reset of the value
- (4) Input the value equivalent to 100% value of the input range to the distributor.

- (5) Read the parameter **[C05: SPAN ADJ]** and check the input value.
- (6) Adjust the span in the same way as (3).

#### Output Adjustment Procedure

When adjusting 0% value of output:

- (1) Set the adjustment value 0% in the parameter **[C01: OUT 0%]**.
  - The value equivalent to 0% of the output range will be output, irrespective of the input.
- (2) Check the output value via digital multimeter, and adjust it in the parameter **[C01: OUT 0%]**.
  - If the indicating value of DMM deviates to the (+) side, set (-) value equivalent to the deviation; if it deviates to the (-) side, set (+) value equivalent to the deviation for adjusting the output value to 0%.

\*: The 100% value of output can be adjusted by the same operation as in **[C02: OUT 100%]**.

For adjustment using a setting tool, refer to the User's Manual for each setting tool and "5. List of Parameters" in this manual.

User's Manual for VJ77 [Document No.: IM 77J01J77-01E]; however, use the VJ77 of version R1.05 or later.

User's Manual for JHT200 [Document No.: IM JF81-02E]